

Product Information

Type 8287 Pneumatic Grips for Temperature Chambers, Fmax 1 kN

CTA: 39607 39552

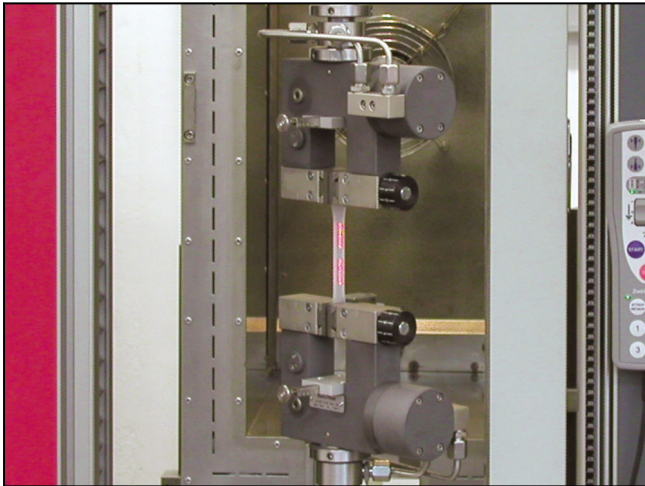

Type 8287 pneumatic grips for temperature chambers, Fmax 1 kN, single actuator

Applications

- Specimen material:
Plastics, paper, textiles, elastomers, insulation, wood
- Specimen shape:
Round and flat specimens, asymmetrical specimens
- Type of loading:
Tensile

Function description

These pneumatic grips are single or double-actuator grips specifically designed for use in temperature chambers.

The single-actuator grips can be used for both symmetrical and asymmetrical clamping. The opposing jaw features stepless adjustment.

Double-actuator specimen grips always close symmetrically to the tensile axis, eliminating the need for thickness adjustment.

The gripping pressure for the specimen grip can be set steplessly and reproducibly via a pneumatic control unit and optionally via the testXpert III testing software. The specimen is held securely and jaw breaks are prevented during the test.

The specimen grip is opened and closed via buttons on the testing machine. The optional foot pedal unit or machine remote control can be used for additional operating convenience.



Type 8287 pneumatic grips for temperature chambers, Fmax 1 kN, double actuator

The maximum opening width/gripping force can be changed by repositioning a pin:

- large opening width -> low gripping force
- small opening width -> high gripping force

Pneumatic specimen grips are ideal for clamping-sensitive materials or if a high specimen throughput is required. The gripping force always remains constant, regardless of test load.

These specimen grips have special connection units for use in the temperature chamber with integrated compressed air supply.

A receptacle for condensation water serves as a drainage system to remove condensation from the test area. The height of the connection units is dependent on the following:

- Materials testing machine
- Temperature chamber
- Specimen-dependent stroke ratios in the temperature chamber

Therefore the connection units are determined according to the project.

Advantages and features

- Constant pneumatic pressure allows even specimens prone to shrinkage to be held securely.
- Constant gripping force enables repeatable test results to be achieved.
- The jaws can be changed quickly and easily for different applications - no tools required. The jaws are centered automatically.

PI 692 524

Product Information

Type 8287 Pneumatic Grips for Temperature Chambers, F_{max} 1 kN

- Precise test results combined with high number of cycles achieved through centric insertion of specimen using easily adjustable centering stop.
- Adjustable opposing jaw for fast, easy testing, including joined (asymmetrical) specimens
- Ergonomic, open design for fast, easy specimen insertion and clamping

Technical data

Item No.	1106804	
Type	8287	
Test load F _{max}	1/0.5	kN
Operating pressure	0.5 ... 10	bar
The operating pressure is dependent on the upstream components.		
Gripping force at 6 bar		
Opening width range 1, approx. ¹⁾	1	kN
Opening width range 2, approx. ¹⁾	0.6	kN
Gripping force at 10 bar		
Opening width range 1, approx. ¹⁾	1.8	kN
Opening width range 2, approx. ¹⁾	1	kN
Opening width with jaws, 5 mm thickness		
Range 1 ¹⁾	0 ... 12	mm
Range 2 ¹⁾	0 ... 22	mm
Gripping travel of pneumatically operated side		
with 12 mm opening width	6	mm
with 22 mm opening width	11	mm
Gripping of the specimen	The specimen must be gripped with at least 2/3 of the jaw height.	
Dimensions		
Height	180	mm
Width	196	mm
Depth	65	mm
Depth with pneumatic tubes	101.5	mm
Connection, hole	Ø 20	mm
Weight per specimen grip, approx.	2.5	kg
Ambient temperature	-70 ... +250	°C
Scope of delivery	2	piece(s)

¹⁾ The opening width is the result of using jaws with 5 mm jaw thickness.

Product Information

Type 8287 Pneumatic Grips for Temperature Chambers, F_{max} 1 kN

Item No.	1106805	
Type	8287	
Test load F _{max}	1/0.5	kN
Operating pressure	6 ... 10	bar
The operating pressure depends on the upstream components.		
Gripping force at 6 bar		
Opening width range 1, approx. ¹⁾	1	kN
Opening width range 2, approx. ¹⁾	0.6	kN
Gripping force at 10 bar		
Opening width range 1, approx. ¹⁾	1.8	kN
Opening width range 2, approx. ¹⁾	1	kN
Opening width with jaws, 5 mm thickness		
Range 1	0 ... 12 ¹⁾	mm
Range 2	0 ... 22 ¹⁾	mm
Gripping of the specimen	The specimen must be gripped with at least 2/3 of the jaw height.	
Dimensions		
Height	180	mm
Width	240	mm
Depth	65	mm
Depth with pneumatic tubes	140	mm
Connection, hole	Ø 20	mm
Weight per specimen grip, approx.	2.8	kg
Ambient temperature	-70 ... +250	°C
Scope of delivery	2	piece(s)

¹⁾ The opening width is the result of using jaws with 5 mm jaw thickness.

CTA: 283778 283933

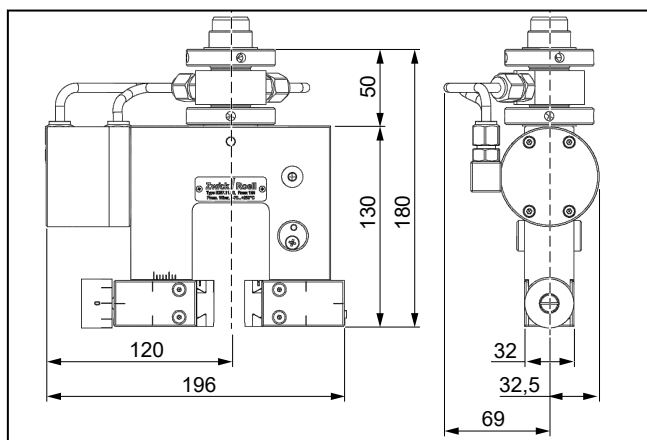

Type 8287 pneumatic grips, F_{max} 1 kN, single actuator: general view

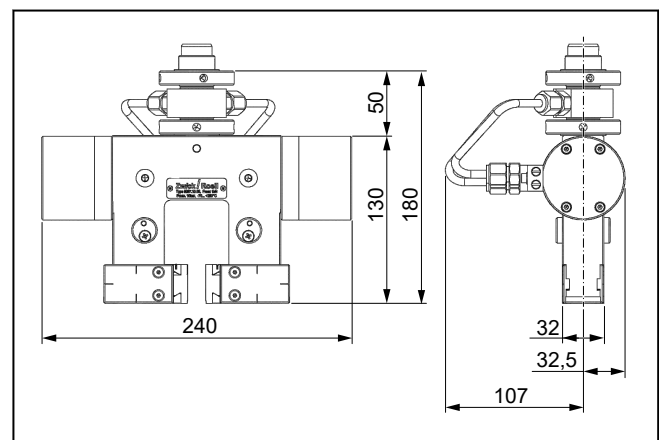

Type 8287 pneumatic grips, F_{max} 1 kN, double actuator: general view

Product Information

Type 8287 Pneumatic Grips for Temperature Chambers, Fmax 1 kN

Accessories required

Pneumatic hoses (1x required)

Description	ArticleNumber
Set of pneumatic hoses for connecting a pair of pneumatic grips; including hose guiding for strain relief	1112640

Pneumatic control unit

See section 4.6 Accessories

Jaws

Type 8287 or type 8487

Optional accessories

Pressure amplifier

Description	ArticleNumber
Pressure amplifier for increasing operating pressure, max. input pressure 10 bar, pressure ratio 1:2, flow rate 900l/min, output pressure 2 - 10 bar. For installation in control unit line.	315016
Pressure amplifier for increasing operating pressure, max. input pressure 10 bar, pressure ratio 1:2, flow rate 400l/min, output pressure 2 - 20 bar. For installation in control unit line.	315018

Dryer unit

Description	ArticleNumber
Dryer unit with pre-filter for pneumatic grips for temperature chambers. Dryer unit is required to prevent condensation within the grips during tests in a temperature chamber at temperatures below 0°C.	315014

The insertion aid can only be used in combination with the following double-acting pneumatic grips:

- Pneumatic grips type 8187, Fmax 200 N (ArticleNumber 1106792) and type 8287, Fmax 1 kN (ArticleNumber 1106793)
- Pneumatic grips for temperature chambers type 8287, Fmax 1 kN (ArticleNumber 1106804)
- Pneumatic grips type 8297, Fmax 2.5 kN (ArticleNumber 1106794) and type F8297, Fmax 2.5 kN (ArticleNumber 1106831)

Insertion aid for foil/film specimens, 1x required

For optimal alignment and secure insertion of thin flexible foils/films made of metal or plastic into the specimen grip.

Description	ArticleNumber
Insertion aid for foil/film specimens; width: 10...25.4 mm, length: 210 mm, L0: 100 mm	1115929
Insertion aid for foil/film specimens; width: 10...25.4 mm, length: 160 mm, L0: 50 mm	1127183

Insertion station for foil/film specimens, 1x required

For attaching the insertion aid for quick and easy insertion of the foil/film specimen into the insertion aid.

Description	ArticleNumber
Insertion station for foil/film specimens; width: 10...25.4 mm, length: 210 mm, L0: 100 mm	1115928
Insertion station for foil/film specimens; width: 10...25.4 mm, length: 160 mm, L0: 50 mm	1127181

Adapter, 1x required

Description	ArticleNumber
Adapter for optimal alignment and quick insertion of the insertion aid.	1115930

Product Information

Type 8287 Pneumatic Grips for Temperature Chambers, Fmax 1 kN

Insertion aid distance block for adapter, 1x required

Determines the distance between the specimen center and test axis center and is attached to the adapter.

Description	ArticleNumber
Insertion aid distance block for 10 mm specimen width	1127184
Insertion aid distance block for 12.5/12.7 mm specimen width	1127185
Insertion aid distance block for 15 mm specimen widths	1127186
Insertion aid distance block for 20 mm specimen width	1127187
Insertion aid distance block for 25/25.4 mm specimen width	1127188

Transport frame

Description	ArticleNumber
Transport frame for depositing five insertion aids.	1127189