

Product Information

HIT450P/HIT300P Pendulum Impact Tester for Metal Specimens

CTA: 205794 206318



Pendulum impact tester HIT450P

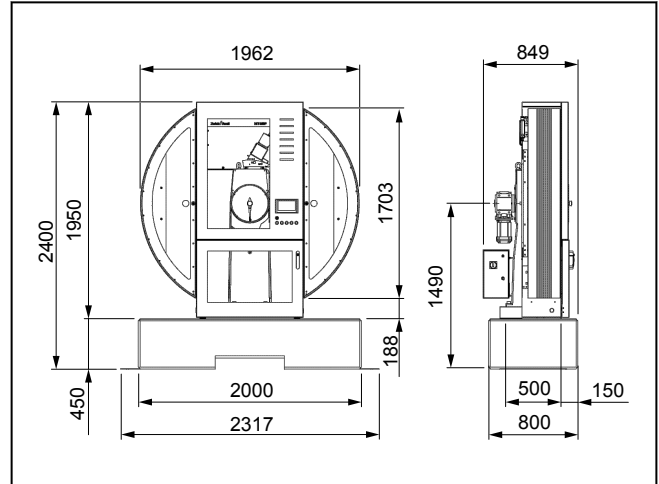

Pendulum impact tester HIT450P, dimension

Range of application

The HIT450P / HIT300P is a universal pendulum impact tester and can be used for a wide variety of different types of test. Modular design and comprehensive accessories make it well suited to the requirements of research, development and quality assurance.

The HIT450P / HIT300P can be used for tests to the following standards: ISO 148-1, ASTM E23, BS131-1, JIS Z 2242, GOST 9454-78, DIN 50115 (withdrawn).

- Impact bending tests on metals (Charpy, Izod – conventional and instrumented)
- Impact tensile tests on metals
- Bruggen tests to verify the wear-behavior of transmission gears
- Wedge impact test to determine the strength properties of structural adhesives

Advantages and features

The HIT 450P / HIT 300P pendulum impact tester is the result of close cooperation with users and 160 years of experience in developing pendulum impact testers.

Short test cycles

- Fast, standard-compliant specimen insertion
- Specimen remains can be removed selectively
- Semi-automatic centering of Charpy specimens

The new user interface saves time and money

- Training is unnecessary: ZwickRoell testing machines and instruments are operated with the same user interface and logic.
- Plug and play: Common standards are already set up in the ZwickRoell testing software.

Reliable test results

- Plausibility check of test results enabled by a combination of electronic and analog displays
- The air and bearing friction of the pendulum hammer and the friction of the analog display drag pointer are determined and evaluated with support from the software.
- Transmission errors are eliminated: Measurement data from the caliper are read-in directly; test series can be transmitted to a PC via a USB port

Reduced operating costs

- Four-way anvils
- Patented impact fixture
- Top material matched to specimen material available

Future-proof

- Izod, Charpy, impact tensile and instrumentation possible in one instrument
- ISO 13849-1 safety requirements are dependably satisfied

Safety and ergonomics

- Complies with the requirements of ISO 13849.
- For repeatable test results, precise positioning of the specimen is vital.
- Large windows allow for a clear view of the specimen.
- Test area lighting makes precise positioning of the specimen easier. The very bright illumination of the test area exceeds the work place requirement.
- The intelligent coupling always catches the pendulum in the highest position. This reduces wear and test time.

PI 732 0919

Product Information

HIT450P/HIT300P Pendulum Impact Tester for Metal Specimens

- The door for the HIT450P can be adapted according to customer requirements. It is available in sliding and hinged version. This can, for example, allow for work in a seated position.
- The central arrangement of all user elements optimizes the workflow.

An operational instrument comprises:

- basic instrument, electro-magnetic pendulum hammer release, electrically operated pendulum lift, electrical safety device and safety housing
- test-specific accessories such as Charpy fixture, support, pendulum rod with hammer, tongs for Charpy specimens
- wear parts such as anvils and tups
- optional accessories, e.g. PC equipment, temperature-conditioning devices

Function description

The basic instrument is equipped with many functions. Automatic pendulum lifting and the electro-magnetic pendulum release increase operating comfort and avoid user errors. Two large wing doors provide access to the tup and anvils, so that cleaning and modification tasks can be conveniently performed. The specimen can be quickly and easily inserted through the large hinged door on the front. This makes it possible to stay within the preset test time of 5 seconds for temperature-conditioned specimens with no problem. For work in an ergonomic seated position, a sliding door is available as an alternative. All doors are equipped with safety monitoring to ISO 13849-1 and correspond with the safety requirements of the EG Machinery Directive 2006/42/EG, EN ISO 12100 and EN ISO 13849-1/2.

Analog/digital display

Two systems, which can also be used in combination, are available for the determination of the impact energy:

Analog display: The analog display of the HIT450P/HIT300P directly indicates the absorbed impact energy in joules. Conversion of the scale units is not necessary, because based on the energy of the hammer, corresponding scales are mounted on the dial. The parallax, free display repeatably presents the measurement results. The robust mechanical design and ease of operation have proven themselves at ZwickRoell for decades.

Digital display/instrument electronics The high resolution instrument electronics enable standard-compliant testing with a 450 J hammer starting at 1.5 J. The smallest impact energies are recorded with accuracy. Changing pendulums to lower energy values is unnecessary, eliminating set-up time. In connection with the electro-mechanical pendulum release the system works operator-independently and provides reliable test results. The electronics support common calibration methods with the Help function and are prepared to operate with a PC and testXpert III.

Tip: Especially in the case of test results for specimen materials with large scatter, a combination of analog display with the instrument electronics is useful. This allows for a plausibility check after every impact.

CTA: 168995

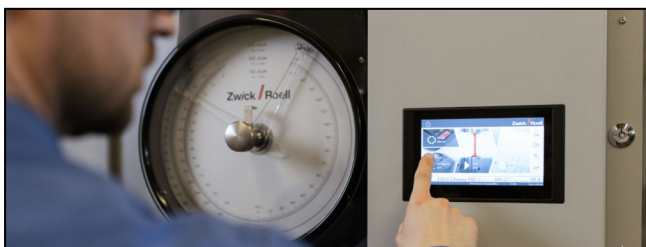

Analog and digital display

Product Information

HIT450P/HIT300P Pendulum Impact Tester for Metal Specimens

Impact fixtures

As standard, the HIT450P/HIT300P is delivered with a universal impact fixture which, with its wide range of functions, enables operation to Charpy and Izod. For higher test volumes the special patented Charpy Fixture Plus is available. At 100 hits per day, these pay for themselves in one year.

CTA: 45831

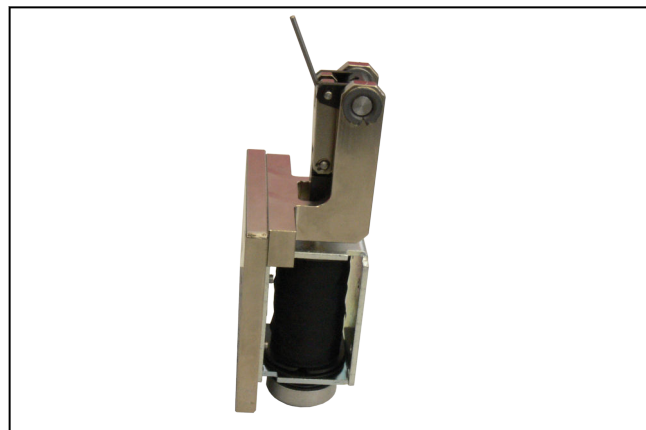

Notch alignment unit

Pendulum height adjustment

The height adjustment system allows variable adjustment of the impact velocity and energy in 2.5° steps, enabling impact velocities from just 0.12 m/s.

Concrete base

For standard-compliant operation of a pendulum impact tester the mass of the base must amount to 40 times the pendulum energy. For efficient operation ZwickRoell recommends the concrete base specially manufactured for the HIT450P/HIT300P. The instrument is permanently set up using leveling units and casting compounds, so that a clean calibration is ensured. Alternatively, reinforcing steel bars are available for in-house construction of the concrete base.



Concrete base

Instrumented tests

In instrumented tests the force is measured during the impact. The result obtained is in the form of a force-time curve. All the required components can be selected or retrofitted on a modular basis. The sampling rate of ZwickRoell measurement electronics is 4 MHz and is three times as high as the basic physical principles require. This allows an extremely high level of fidelity to be achieved for high-speed processes.

Deformation measurement

Deformation can be determined indirectly via a calculation method. Because the impacting mass is

CTA: 183947

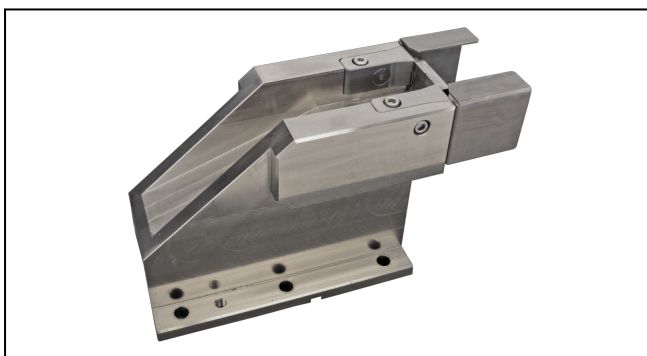

Charpy Fixture Plus

Pendulum hammer

In some standards the specimen break energy is assigned to a pendulum hammer energy. Accordingly, for the HIT450P/HIT300P, the pendulum hammers are available in 50 J, 150 J, 300 J and 450 J.

CTA: 168994



Pendulum hammer 450J

Centering device

With the semi-automatic specimen centering device the Charpy specimen can be aligned directly to the notch. The centering cone disappears automatically, immediately upon release of the pendulum hammer. This ensures that the specimen does not slide out of place when closing the door. Alternatively, the specimen can be aligned using a lateral device.

CTA: 170625

Product Information

HIT450P/HIT300P Pendulum Impact Tester for Metal Specimens

known, the displacement on impact can be calculated via a double integration method. This method is commonly used and is permitted for evaluation in most standards. It offers good travel resolution and accuracy. This method eliminates the need for expensive high-speed travel-measuring instruments which are not necessarily more accurate.

Anvil/tup

Wear to tups and anvils can be reduced by selecting appropriate materials. Available from ZwickRoell is a wide range of different materials. Based on experience it has been possible to determine the following guide values for the average life expectancy of anvils and tups with specimens of low-alloy iron-based materials.

Anvils made of S1 materials can be supplied on request. These are special materials developed by ZwickRoell for the most demanding applications and display outstanding wear properties, particularly with specimen materials made of high-alloy and corrosion-resistant steels.

Interior Illumination for the HIT450P

The interior illumination makes precise positioning of the specimen easier, which helps achieve repeatable test results. Due to the bright illumination at 2000 Lux, it exceeds the workplace requirements according to ASRA3.4.

Guide values for average life expectancy of anvils and tups with specimens of low-alloy iron-based materials

As referred to above, these values may be exceeded in individual cases, but may also fail to be attained by a considerable margin. In extreme cases single tests can result in anvils becoming unfit for further use.

	Recommendations		Experience
	Inspect after number of tests	Replace after number of tests	Average service life/ number of tests
Anvil			
TS	50	1500	3000
HSS	100	3500	7000
PM	150	7000	14000
Tup			
TS	200	9000	18000
PM	300	15000	30000

Number of Charpy tests if anvils and tups are regularly and well maintained, with absorbed impact energies below 80% of the nominal initial potential energy of the pendulum impact tester in use.

Technical data

Type Item No.	HIT450P 1064344	HIT300P 1064346	
Nominal potential energy	450	300	J
Drop height	1.3969	1.3969	m
Impact velocity	5.23	5.23	m/s
Weight			
Depending on pendulum hammer used	590 ... 610	590 ... 610	kg
Concrete base	1600	1600	kg
Safety device	90	90	kg
Dimensions, with base			
Height	2450	2450	mm
Width	2317	2317	mm
Depth	850	850	mm

Product Information

HIT450P/HIT300P Pendulum Impact Tester for Metal Specimens

Type Item No.	HIT450P 1064344	HIT300P 1064346	
Interfaces	USB, RS 232	USB, RS 232	
Ambient temperature	+10 ... +35	+10 ... +35	°C
Temperature during storage and transport	-25 ... +55	-25 ... +55	°C
Relative humidity (non-condensing)	20 ... 90	20 ... 90	%
Test results, numerical	Impact energy [%], impact energy [J], impact strength [KJ/m ²]		
Output units	Analog dial display		
Pulse resolution	0.036	0.036	°
Power input specifications			
Power supply	400	400	V
Phases	3Ph/N/E	3Ph/N/E	
Permissible voltage fluctuation	±10	±10	%
Power consumption (full load), approx.	1	1	kVA
Power frequency	50/60	50/60	Hz

Accessories

To specify suitable accessories for your testing requirements please contact our Sales Department.